



**OVERVIEW:** This is a basic installation and commissioning steps that must be adhere for quick installation and commissioning.

### STEP 1 - UNPACK INSPECTION

**Check the following after receiving the product. If found abnormalities, please contact the local dealer or Kruger office.**

- 1.1 Check if the packing box is damaged.
- 1.2 Check if the interior surface of the packing box is abnormal. For example, in wet condition or whether the enclosure of the VFD is damaged or cracked.
- 1.3 Check if the accessories inside the packing box are complete (including the manual and keypad).
- 1.4 Check if the VFD nameplate is consistent with the model identifier on the exterior surface of the packing box and your purchased model.

**Model:** K320-004P-4      IP20

**Power:** 4.0kW

**Input:** AC 3PH 380(-15%)~400V(+15%) 13.5A  
47Hz~63Hz

**Output:** AC 3PH 0-Uinput 9.5A 0-400Hz

---

**S/N:** \_\_\_\_\_      Made in China

**Kruger Ventilation Industries Asia Co., Ltd.**

**K320 - 004P - 4**  
①   
②   
③

Figure 3-2 Model description

Field	No.	Description	Content
Abbreviation of product series	①	Abbreviation of product series	K: Kruger 3: Three phase 20: ingress protection (IP) rating, IP20
Rated power	②	Power range + load type	004: 4kW P: Variable torque load
Voltage class	③	Voltage class	4: AC 3PH 380V(-15%)~440V(+10%)

### STEP 2 - INSTALLATION CONFIRMATION

**Check the following before VFD installation.**

- 2.1 Ensure that the grid voltage meets input power of VFD.
- 2.2 Ensure that the output power from VFD is matched with the motor spec.
- 2.3 Ensure that the environments of installation area are not over the VFD specified limits.

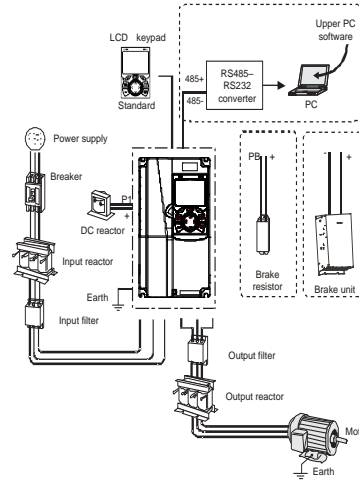

**Check the following after the VFD installation.**

- 2.4 Ensure that the correct accessories are selected for the VFD. The accessories are correct and properly installed, and the installation cables meet the requirements of all components (including the reactor, input filter, output reactor, output filter, DC reactor, braking unit and braking resistor).
- 2.5 Ensure that all control cables and power cables are run separately and the routing complies with EMC requirements.
- 2.6 Ensure that all grounding systems are properly grounded according to the requirements of the VFD.
- 2.7 Ensure that the external connection terminals of the VFD are tightly fastened and the torque on the bolts are appropriate.
- 2.8 Ensure that there are screws, cables, or other conductive items are cleared from the VFD. If no, clear them out.

### STEP 3 - BASIC COMMISSIONING

Complete the basic commissioning below before the actual use of the VFD. (See more details in page no. 2)

**3.1 MOTOR SETTING & AUTO TUNING**

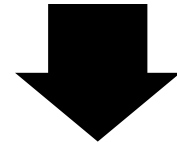

**3.2 CONTROL METHOD & SETTING**



**CAUTION:** The K320 should ONLY be installed by a qualified electrician.

**DANGER!** Improper wiring can and will cause bodily harm as well as damage to the equipment.



### 3. BASIC COMMISSIONING (CONTINUE)

You can perform various operations on the VFD by using the keypad, including entering/exiting menus, parameter selection, list modification and parameter addition.



### 3.1 MOTOR SETTING & AUTO TUNING

#### 1. Select the motor type

Push Manu => Parameter setting => Motor and Encoders parameter setting => Motor1 param => P02.00 motor type (0: Asynchronous motor, 1: Synchronous motor)

#### 2. Set motor parameters follow Motor's nameplate

- Asynchronous motor\_P02.01 to P02.05

##### Example of setting

3-PH INDUCTION MOTOR			
Label	Value	Unit	Setting
2 POLE	FS	100L	IP 55
4.0	HP	87.1	INS. CL. F
3.0	KW	PF 0.87	Temp. Cl
50	Hz	400	V Y V
2280	RPM	5.7	A Y A
CONT. RATING BRG.			
IEC 60034-1	WT	38.0	KG

- P02.01: Rated Power (3.0 kW)
- P02.02: Rated Frequency (50 Hz)
- P02.03: Rated Speed (2880 rpm)
- P02.04: Rated Voltage (400 V)
- P02.05: Rated Current (5.7 A)

- Synchronous motor\_P02.15 to P02.19

##### Example of setting

Permanent Magnet Motor			
Label	Value	Unit	Setting
2 POLE	FS	90L	IP 55
6.5	HP	88.8	INS. CL. F
4.77	KW	PF 0.99	Temp. Cl
50	Hz	V Y 400	V
3000	RPM	A Y 12.5	A
CONT. RATING BRG.			
IEC 60034-1	WT	32.0	KG

- P02.15: Rated Power (4.77 kW)
- P02.16: Rated Frequency (50 Hz)
- P02.17: Number of pole pair (1)\*
- P02.18: Rated Voltage (400 V)
- P02.19: Rated Current (12.5 A)

\* 2 pole = 1 pole pair

#### 3. Auto tuning

De-couple the load from motor before start autotuning.

Push Manu => Motor parameters auto tuning =>

1: Rotary auto tuning => Push RUN to start auto tuning

=> Waiting until tuning completed

**Note:** If cannot be de-coupled motor from the load, please select to perform 2: Static autotuning.

#### 4. Check rotating direction

Push Jogging for 5sec to run motor and check whether the motor rotational direction is correct. If not, change the rotation direction by swapping U↔W wires of the motor. or change P00.13 from 0 to 1: Run in reverse direction.

### 3.2 CONTROL METHOD SETTING

#### 1. Select Start/Stop command method

Push Manu => User defined parameter setting => P00.01: Run CMD channel (0: Keypad, 1: Terminal, 2: Communication)

P00.01 = 0 : Start/Stop via Keypad

- You can Push or on Keypad directly.

P00.01 = 1 : Start/Stop via Terminal

- Connect 3 switch to terminal S1, S2, S3, COM, PE below.

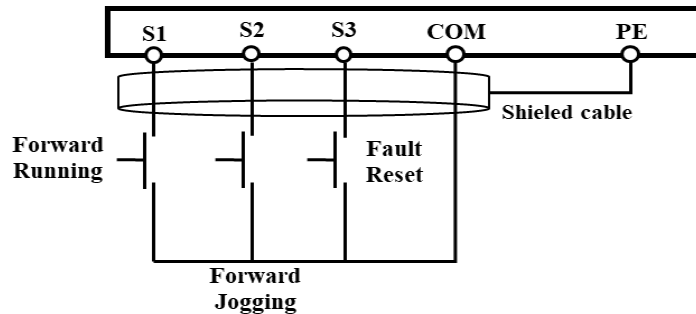

P00.01 = 2 : Start/Stop via Communication (Modbus)

- Connect control cable to 485+, 485-, 485G below.

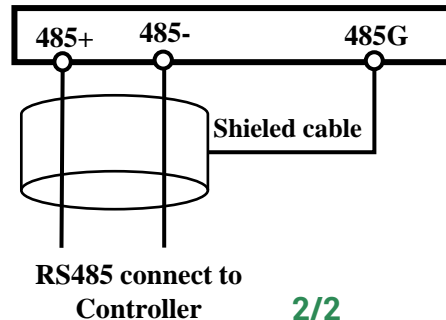

#### 2. Select Speed command method

Push Manu => User defined parameter setting

=> P00.06: A Freq CMD

(0: Set via Keypad, 1: Set via AI1)

P00.06 = 0 : Set via Keypad

- You can adjust motor speed / frequency from the Digital Operator on Keypad directly.



P00.06 = 1 : Set via AI1

- Speed reference from external terminals (Potentiometer or Analog Signal)

Connect cable to 10V, AI1, GND, PE below.

